

**SCHEMI di LAVORAZIONE GRUPPI per PERLINE**

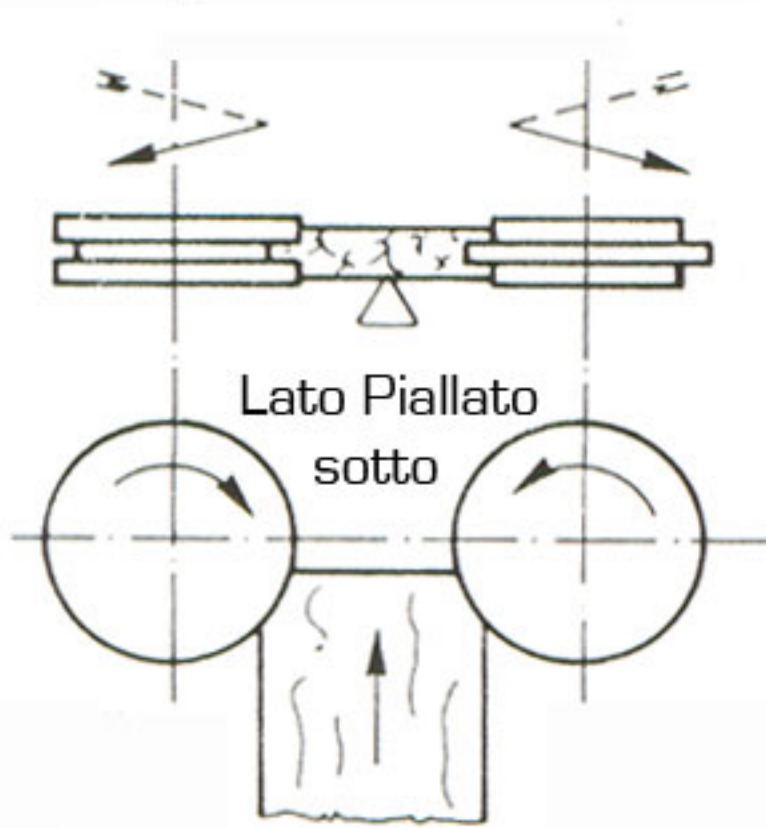

**Costruzione:** a 2 taglienti e 2 dentoni, in HW o WS.

**Fig.1**



**Fig.2**

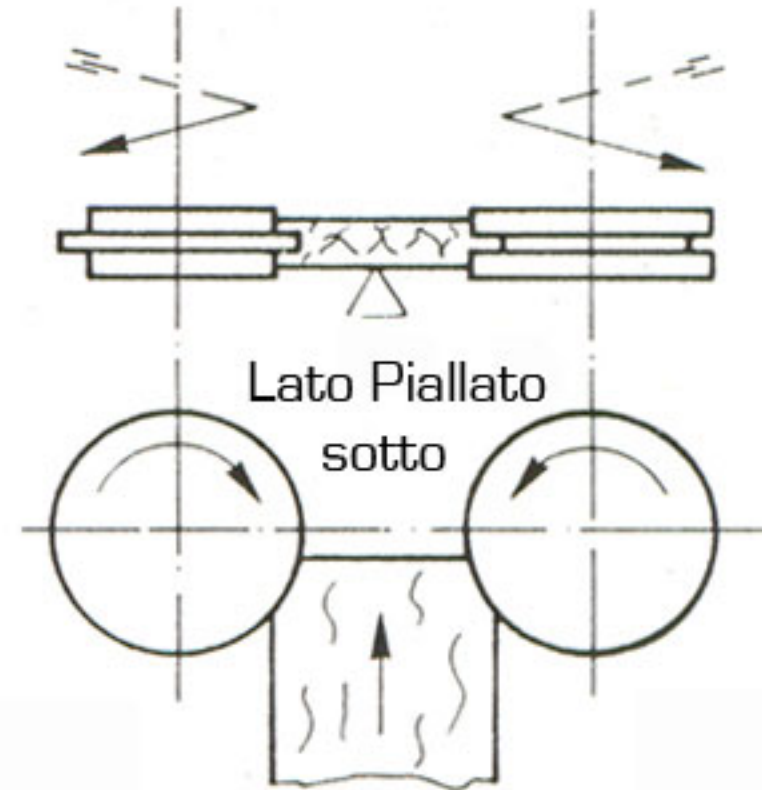

**Fig.3**

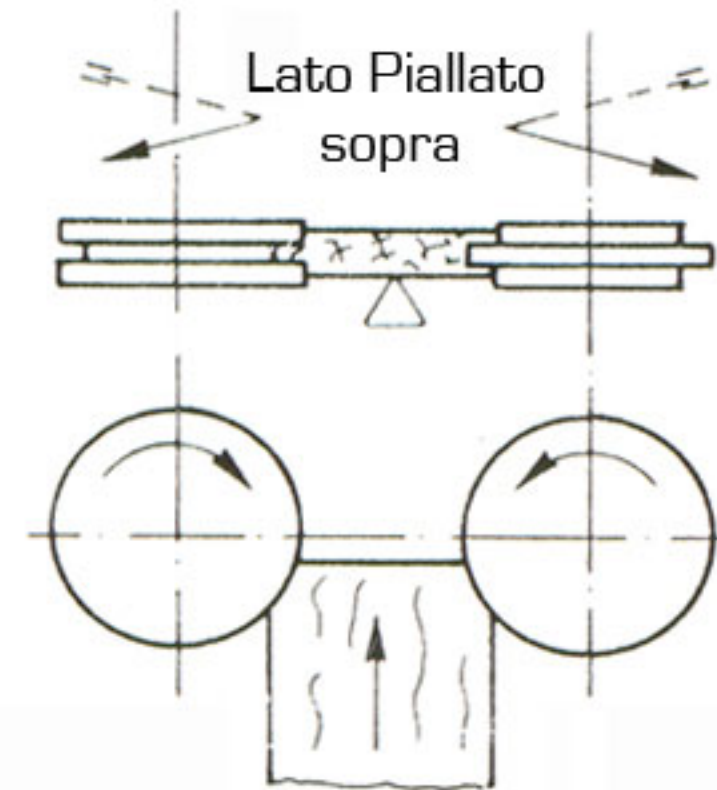

**Fig.4**

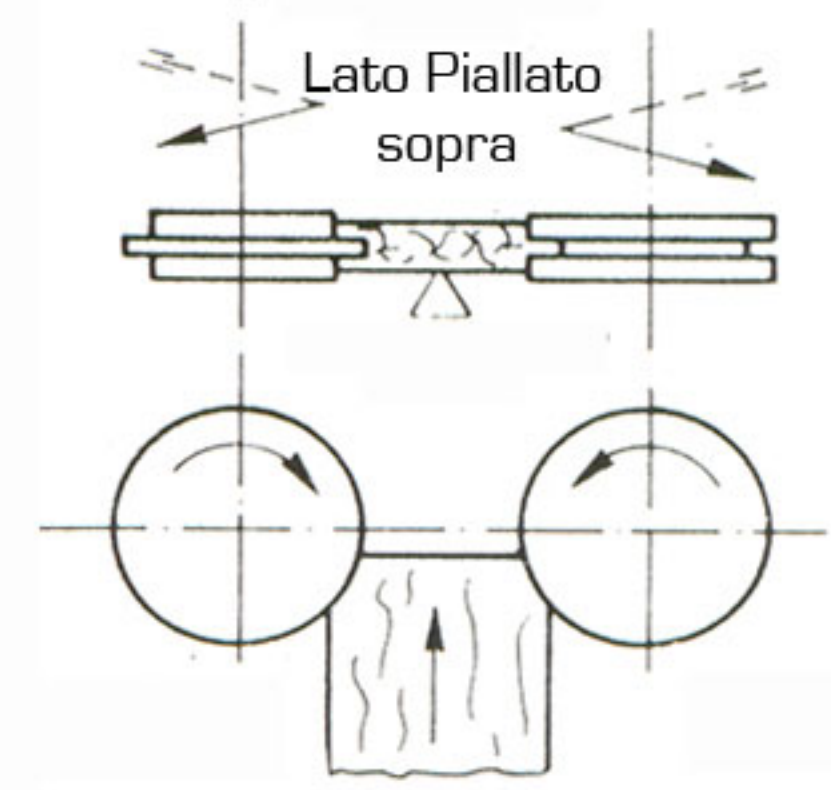

*Gruppi Frese per Parchetti*

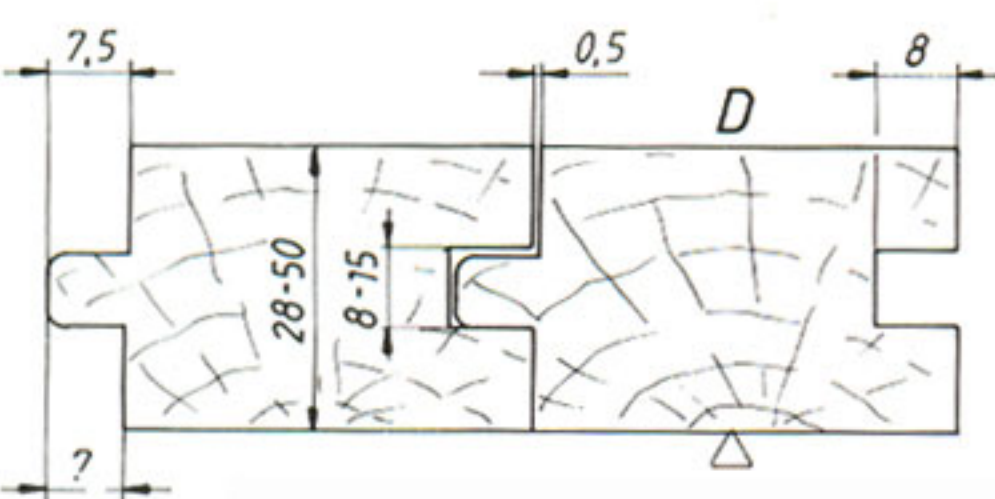
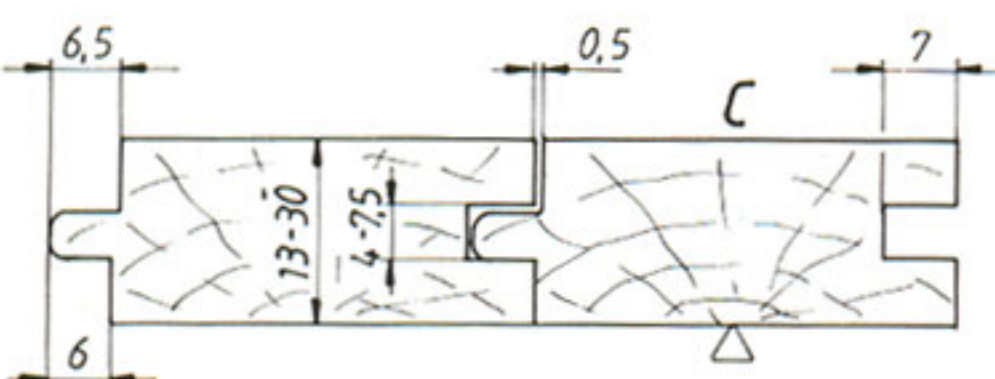
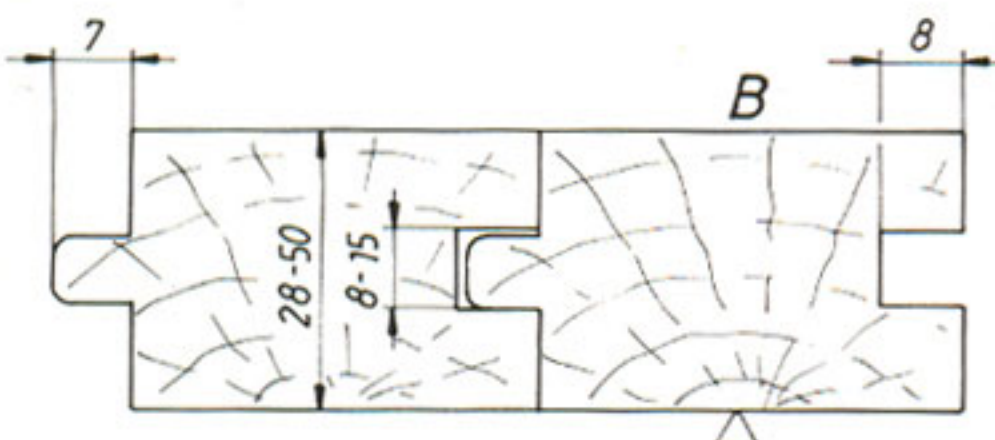
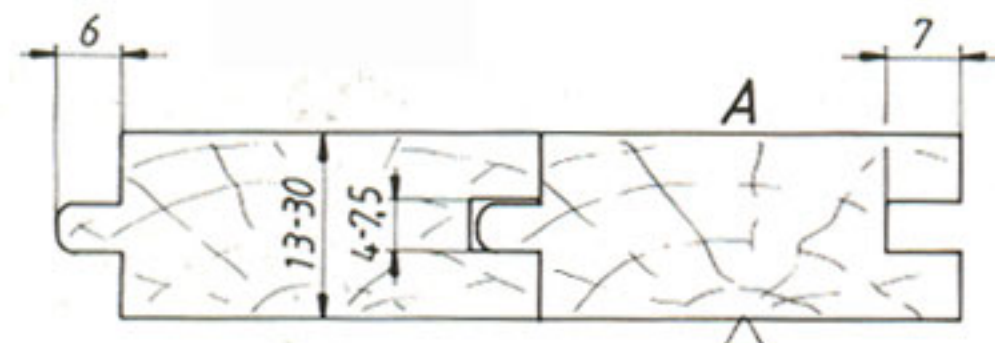

D	B	PROF.	Codice HW / WS
140	30	A	TD230.A1
140	35	B	TD230.B1
160	30	A	TD230.A2
160	35	B	TD230.B2
180	30	A	TD230.A3
180	35	B	TD230.B3
140	30	C	TD230.C1
140	40	D	TD230.D1
160	30	C	TD230.C2
160	40	D	TD230.D2
180	30	C	TD230.C3
180	40	D	TD230.D3

**NB:** LA COSTRUZIONE STANDARD PREVEDE IL GRUPPO MASCHIO DESTRO ED IL GRUPPO FEMMINA SINISTRO CON IL LATO PIALLATO SOTTO (FIG.1). SENZA NESSUNA INDICAZIONE SULL'ORDINE, VIENE FORNITO COME DA FIG.1